

Medical / ITE Open Frame



Features

- 3" x 2" Compact Size
- 2 x MOPP, IEC/EN60601-1 Compliance
- Protections:
Short circuit / Over voltage / Over current
Over temperature
- Energy Efficiency $\geq 88\%$ ~91% depends on models
- No Load Power Consumption $\leq 0.15W$
- MTBF > 100,000 hours
- Low leakage Current
- Customized Solutions Available

EPM106A U - XX YY

- U:** Output range
XX: Specified output voltage, i.e. 12 is 12VDC
YY: Differential segmentation

General Specification

OUTPUT

MODEL No.	MAX. OUTPUT POWER (W)	OUTPUT VOLTAGE (Vo)	MIN. LOAD (Io)	MAX. LOAD (Io)	LOAD REGULATION	LINE REGULATION	RIPPLE & NOISE
EPM106AA	45W	12~15V	0A	3.75A	$\pm 2\%$	$\pm 0.5\%$	200mV
EPM106AB	45W	19~24V	0A	2.36A	$\pm 1\%$	$\pm 0.5\%$	300mV
EPM106AC	45W	28~36V	0A	1.6A	$\pm 1\%$	$\pm 0.5\%$	450mV
EPM106AD	45W	48~56V	0A	0.93A	$\pm 1\%$	$\pm 0.5\%$	600mV
EPM106AE	50W	12~15V	0A	4.16A	$\pm 2\%$	$\pm 0.5\%$	200mV
EPM106AF	50W	19~24V	0A	2.63A	$\pm 1\%$	$\pm 0.5\%$	300mV
EPM106AG	50W	28~36V	0A	1.78A	$\pm 1\%$	$\pm 0.5\%$	450mV
EPM106AH	50W	48~56V	0A	1.04A	$\pm 1\%$	$\pm 0.5\%$	600mV
EPM106AJ	60W	12~15V	0A	5A	$\pm 2\%$	$\pm 0.5\%$	200mV
EPM106AK	60W	19~24V	0A	3.15A	$\pm 1\%$	$\pm 0.5\%$	300mV
EPM106AL	60W	28~36V	0A	2.14A	$\pm 1\%$	$\pm 0.5\%$	450mV
EPM106AM	60W	48~56V	0A	1.25A	$\pm 1\%$	$\pm 0.5\%$	600mV
EPM106AN	65W	12~15V	0A	5.41A	$\pm 2\%$	$\pm 0.5\%$	200mV
EPM106AP	65W	19~24V	0A	3.42A	$\pm 1\%$	$\pm 0.5\%$	300mV
EPM106AQ	65W	28~36V	0A	2.32A	$\pm 1\%$	$\pm 0.5\%$	450mV
EPM106AS	65W	48~56V	0A	1.35A	$\pm 1\%$	$\pm 0.5\%$	600mV

NOTE:

- 1 : Ripple & Noise is measured by using 20MHz bandwidth limited oscilloscope and terminated each output with a 0.1uF ceramic capacitor & parallel with 47uF aluminum capacitor at full load and nominal line.
- 2 : Line regulation is defined by changing $\pm 10\%$ of input voltage from nominal line at rated load.
- 3 : Max. Power (W) $\geq V_o \times I_o$

INPUT

- Input Range: 100 to 240 VAC
- Frequency: 50 to 60Hz
- Input Current: 2A to 0.5A
- Inrush Current: $\leq 120A/230VAC$
- Hold Up Time: $\geq 8.3ms$
- Turn On Time: $\leq 3s$

PROTECTION

- Short Circuit Protection: Auto Recovery
- Over Current Protection: Auto Recovery
- Over Voltage Protection: Auto Recovery
- Over Temperature Protection: Auto Recovery

ENVIRONMENT

- Operating Temperature: -20 to 50°C
- Storage Temperature: -20 to 85°C
- Operating Humidity: 10% to 90 %
- Storage Humidity: 5% to 95 %

DERATING CURVE

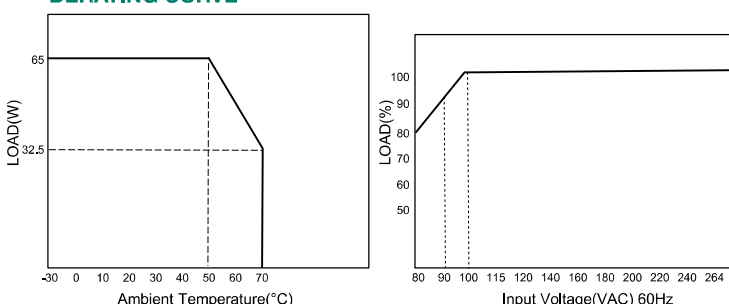

MECHANICAL

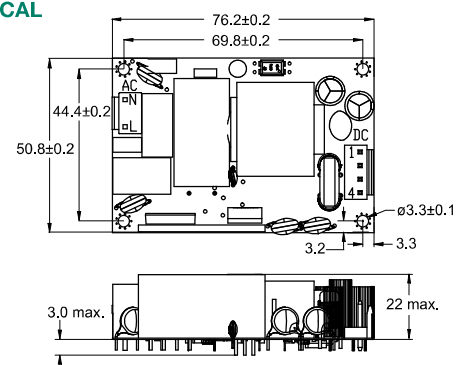

- Mechanical Size: 76.2L x 50.8W x 22H (mm)
- AC Input Connector: JST VHR Series or equivalent
- DC Output Connector: JST VHR Series or equivalent
- Pin Assignment:

AC Input Connector:

Pin No.	Assignment
1	AC/L
2	No Pin
3	AC/N

DC Output Connector:

Pin No.	Assignment
1, 2	+V
3, 4	-V

- Weight: 110g

SAFETY

- Complied with ANSI/AAMI ES60601-1, CAN/CSA-C22.2 No. 60601-1, TUV EN 60601-1, CB IEC 60601-1, CE EMC(EN 60601-1-2) UL 62368-1, CAN/CSA C22.2 No. 62368-1, TUV EN 62368-1, CB IEC 62368-1, FCC Part 15B, CE EMC(EN 55032+EN 55035), UKCA